





Article

Comprehensive Assessment of Mental Health Stigma

Beatrice-Alice Ciulin¹ , Alicia Pérez-Albéniz¹ , Adriana Díez-Gómez¹ , Beatriz Lucas-Molina²  and Rubén Fernández-Alonso³ 

¹ University of La Rioja (Spain)

² University of Valencia (Spain)

³ University of Oviedo (Spain)

ARTICLE INFO

Received: 11/09/2025

Accepted: 17/11/2025

Keywords:

Mental health stigma
Gender differences
Measurement invariance
University students
SASS

ABSTRACT

Background: Mental health (MH) stigma is one of the main barriers to young people with MH problems seeking help. This study attempts to analyse it using the Stigma and Self-Stigma scales (SASS) in a representative sample of young people, novel aspects being the comprehensive perspective of the instrument used and the analysis of gender effects, both from a psychometric perspective (measurement invariance) and analysis of the differences according to the gender variable. **Method:** 378 students ($M = 20.78$ years; $SD = 1.65$; 61.6% women) participated, selected through a stratified random cluster sampling approach. The scale's internal structure and its measurement invariance between genders were examined. **Results:** The five-factor model of the SASS showed adequate goodness-of-fit indices. Scalar invariance between genders was confirmed for the five-dimensional model, along with higher levels of stigma in several dimensions among boys. Cronbach's α for the different subscales ranged from .62 to .80, and McDonald's ω from .60 to .79. **Conclusions:** The SASS is a brief, simple, and reliable instrument for assessing different dimensions of MH stigma in university settings.

Evaluación Comprensiva del Estigma en Salud Mental

RESUMEN

Antecedentes: El estigma en salud mental (SM) supone una barrera para la búsqueda de ayuda entre jóvenes ante problemas de SM. Este estudio lo analiza mediante la *Stigma and Self-Stigma scales* (SASS) en una muestra representativa de jóvenes, siendo novedosa la perspectiva comprensiva del instrumento utilizado y el análisis de los efectos del género, tanto desde el enfoque psicométrico (invarianza de la medida) como desde el análisis de las diferencias en función de esta variable. **Método:** 378 estudiantes ($M = 20.78$ años; $SD = 1.65$; 61.6% mujeres), seleccionados mediante muestreo aleatorio estratificado por conglomerados, participaron en el estudio. Se examinaron la estructura interna e invarianza de medida en función del género. **Resultados:** El modelo de cinco factores relacionados mostró índices de bondad de ajuste adecuados. Se confirmó la invarianza escalar en función del género para el modelo pentadimensional y la presencia de niveles más altos de estigma en diversas dimensiones en los chicos. El α de Cronbach para las diferentes subescalas varió de .62 a .80 y el ω de McDonald de .60 a .79. **Conclusiones:** El SASS es un instrumento breve, sencillo y fiable para evaluar diferentes dimensiones del estigma en SM en contextos universitarios.

Palabras clave:

Estigma en salud mental
Diferencias de género
Invarianza de medida
Estudiantes universitarios
SASS

Recent studies have increasingly identified the negative effects of stigma on mental health (MH) and people with MH problems (Chukwuma et al., 2024; Mak et al., 2007; Prizeman et al., 2023). Although progress has been made in the field of stigma awareness, there is still a need to dedicate resources to research on the factors that contribute to stigma in order to understand it and improve interventions to address it (Shannon et al., 2020). People with MH problems are a part of society and represent a reflection of its state (Gumus & Avci, 2024). The concept of stigma is intricately linked to that of MH (Zayts-Spence et al., 2023). Consequently, stigma related to MH is a significant global challenge (Abi Hana et al., 2022; Scerri et al., 2023), as it constitutes a major barrier to help-seeking and treatment (Abdelmonaem et al., 2024; Dobransky, 2020; Ferreira-Rodrigues et al., 2025; Paíno et al., 2022). Moreover, the extent and intensity of the MH problems are influenced by sociocultural factors (Ausín et al., 2022; Scerri et al., 2023).

Stigma associated with MH problems or their symptoms encompasses various aspects, including social judgment, degradation, and devaluation of individuals experiencing these challenges (Abdullah & Brown, 2011). Following the investigation of Corrigan et al. (2014), stigma can be classified into three primary types: public stigma, self-stigma, and structural stigma. Public stigma refers to the societal endorsement of negative stereotypes, leading to discrimination against individuals with MH problems. Self-stigma occurs when individuals with MH conditions internalize these prejudices. Lastly, structural stigma manifests in social and institutional policies and practices that restrict opportunities and resources for individuals with MH problems.

Additionally, the beliefs related to MH problems can be presented in many ways, all of which are key to a proper analysis of MH stigma and are described in the following lines (Gray et al., 2023). The first type is stigma towards others or perceived stigma, which refers to the negative beliefs that a person holds in relation to others with MH problems (Pompeo-Fargnoli, 2020), the problems themselves or the use of MH services, all of which are influenced by the social environment (Drent et al., 2022). Social distance encompasses more affective dimensions of stigma, determining the acceptance of people with MH problems within their own community (Martin et al., 2000). Anticipated stigma measures people's thoughts about what the rest of society would think if they had a MH problem (Link, 1987). Self-stigma or personal stigma refers to a person's own thoughts about themselves if they have or were to have a MH problem (Pompeo-Fargnoli, 2020). Some authors also establish the necessity to include between these dimensions the avoidant coping strategies and stigma related to help-seeking behaviours, due to their relevance in the construct of one's MH stigma. The first is characterized by the intentional disregard of one's own difficulties or the inappropriate use of coping strategies in response to challenges, such as substance use, engagement in avoidant or distracting activities, denial, or emotional distancing (Anderson et al., 2024; Fernández-Calderón et al., 2022; Fluharty et al., 2021). Finally, stigma related to help-seeking attitudes reflects individuals' reluctance to acknowledge their difficulties or seek assistance for a MH condition, both from professionals and within their social environment (Goodfellow et al., 2022).

Stigma plays a key role in the social treatment of people with MH problems, affecting at personal, physical, emotional, occupational, familial, and academical spheres (Corrigan et al., 2006; Gumus & Avci, 2024), potentially culminating in instances of social discrimination (Link & Phelan, 2001; Zhang et al., 2020). Moreover,

stigma has a negative influence on people with MH problems by reducing help-seeking and treatment adherence (Corrigan et al., 2006; Dobransky, 2020; Dubreucq et al., 2021; Gumus & Avci, 2024). Primarily, stigma has a direct impact on self-esteem, which can result in some people feeling shame about having a MH problem (Corrigan et al., 2006; Corrigan et al., 2014) or that a family member has one, as well as worry and fear (Dobener et al., 2022), which in turn can lead to the concealment of one's own MH problem (Wang, 2022). Furthermore, there are also negative effects on self-efficacy and self-respect, which can lead to a reduction in resilience (Oexle et al., 2018). The strong correlation between stigma and the development of depression and suicidal ideation is well-documented, so it is important to assess and address stigma in order to reduce its negative effects (Al-Halabí & Fonseca-Pedrero, 2024; Dubreucq et al., 2021; Ward-Ciesielski et al., 2019).

It has been estimated that approximately one quarter of the global population has or will have a MH problem in their lifetime (Nigussie et al., 2023), with the university period being the most significant to its development in more than one quarter of the student population (Leow et al., 2024), which may have repercussions in their future (Grandón et al., 2022; Leow et al., 2024). However, despite the implications mentioned above, there is a certain level of lack of knowledge about stereotypes and prejudices in relation to MH among university students (Ruiz et al., 2022). This can influence students' attitude towards help-seeking (Estupiñá et al., 2024; Kuhlman et al., 2018), as well as showing stigma towards people with MH problems (Ruiz et al., 2022). University plays a pivotal role in raising awareness of MH and demystifying misconceptions surrounding its problems, as it is the final formal educational setting responsible for shaping societal attitudes (Grandón et al., 2022). This highlights the necessity to conduct research into the study of MH stigma at the university stage.

To date, there has been a scarcity of studies that have undertaken a comparative analysis between different university degrees about stigma in MH (Ruiz et al., 2022), being difficult to integrate the entire university population beyond the healthcare field (Chen et al., 2020; Madi et al., 2025; Topkaya, 2021). The majority of these studies focus exclusively on stigma towards others, as evidenced by the work of Sum et al. (2024), who found that elevated levels of stigma are negatively correlated with help-seeking behaviours. In addition, Puspitasari et al. (2020) observed that individuals' contact with MH problems, their experience of help-seeking, and their knowledge of MH problems were all associated with lower levels of stigma. Other studies, such as Al Omari et al. (2021), assessed stigma towards others and self-stigma dimensions, among its results showing that university students exhibited higher levels of stigma in both compared to adolescents. Maeshima and Parent (2022) and Kim and Yon (2019) have analysed these aspects in relation to help-seeking behaviours, with these former studies finding low levels of help-seeking in cases of self-stigma, the latter study identifying a high positive correlation with stigma toward others. In contrast, Shannon et al. (2022) conducted a study exclusively with boys, showing that stigma towards others serves as a stronger predictor of help-seeking compared to self-stigma. Similarly, Chen et al. (2020) identified stigma as a significant barrier to help-seeking among European-American populations.

Regarding gender differences, in most of the studies cited it was displayed that women exhibited lower scores concerning stigma (Al Omari et al., 2023; Dagani et al., 2023; Sum et al., 2024). It is important

to state the lack of studies that evaluate measurement invariance across gender in MH stigma in general population, especially among Spanish students and with Spanish instruments, knowing its relevance for investigation purposes in MH stigma (Sanabria-Mazo et al., 2023). The measurement invariance is necessary to establish comparisons between groups. In general, most studies evaluate the invariance regarding to relatives of individuals with MH problems (Trigueros et al., 2019), culture (Tisocco et al., 2024) or specifically a MH problem, such as eating disorders (Marek et al., 2023) and schizophrenia (Fonseca-Pedrero et al., 2011), but none about gender.

Assessing MH stigma is complex, as it involves measuring procedures that include different areas with interactive variables, as one's own etiological beliefs, attitudes, prejudices, personal and social issues towards people with MH problems and the person themselves, cultural aspects, treatment of MH problems and their causal beliefs, and the distinction between different types of disorders due to their specificity (Mannarini & Rossi, 2019). For this reason, many of the studies carried out at university level only analyse one specific aspect of stigma (Shannon et al., 2020), based on the use of instruments that measure social stigma (Vogel et al., 2009), self-stigma (Ritsher et al., 2003; Vogel et al., 2006), stigma related to help-seeking behaviours (Clement et al., 2012; Vogel et al., 2006), and with specific population, the most common being the health field (Gabbidon et al., 2013; Gaebel et al., 2011; Sastre-Rus et al., 2020). Other instruments analyse the main stigma dimensions related to personal and social stigma, without specifying any dimension that could influence the global stigma toward MH problems, as it is the case of Community Attitudes towards Mental Illness (Taylor & Dear, 1981) or Attitudes Towards Mental Health Problems (Gilbert et al., 2007) scales.

An instrument that adequately addresses the limitations stated above is Stigma and Self-Stigma scales (SASS) (Docksey et al., 2022), which makes a comprehensible approach to the fundamental dimensions of MH stigma, avoiding the excessive use of other instruments, which may lead to study dropout. This instrument showed good psychometric properties in the six-factors model among employees from the UK. The authors question the introduction of the Avoidant coping dimension in the final version. Also, internal consistencies were good for almost all the dimensions. In this regard, SASS displayed consistent results across the measures of MH. However, due to its recent publication, there is no information about its psychometric properties among university students. Also, even though SASS has been validated in previous studies, there is no psychometric evidence in the Spanish context to date.

Given the need to study the MH stigma in the university population, the main objective of this study was twofold: first, to examine the psychometric properties of the SASS scores in a representative sample of Spanish university students, and second, to analyse the influence of gender on the measurement of stigma. The specific aims were to: a) assess the internal structure of the SASS; b) analyse the correlations between the SASS dimensions; c) estimate the reliability of the SASS scores; d) evaluate the scale's measurement invariance by gender, and e) examine differences in stigma based on gender. It was hypothesized that the five-factor model of the SASS would have adequate goodness-of-fit indices, there would be found significant positive correlations between SASS factors, the reliability estimation of the SASS scores would be adequate, and the dimensional model would be invariant across gender.

Method

Participants

The initial sample comprised 381 students from the University of La Rioja (Spain). Participants were asked to indicate their gender and other sociodemographic data. Due to the lack of a minimum number of participants to form groups for non-binary and transgender individuals, three participants were eliminated from the final sample. The sampling method employed was a stratified random cluster sampling approach, utilising year and degree as primary sample units. To obtain the sample size, Slovin's formula was employed [$n = N/(1+Ne^2)$], with an estimation error of 5%. The minimum sample size needed was 349 participants, from a population of 3702 students distributed among the 19 degrees during the academic year 2023/2024 at the University of La Rioja.

The final sample consisted of 378 students. A total of 61.6% of the sample were women, with an average age of 20.78 years ($SD = 1.65$). The sample was proportional to the university population. For instance, 31.0% of the participants came from the Faculty of Letters and Education, and 32.3% were first-year students.

Instruments

Stigma and Self-Stigma Scales (SASS; Docksey et al., 2022). The SASS is an instrument developed to assess MH stigma and comprises 36 core items that evaluate different aspects of stigma, including: Stigma to others (SO), Social distance (SD), Anticipated stigma (AS), Self-stigma (SS), Avoidant coping (AC), and (lack of) Help-seeking behaviours (HS). Each subscale is composed by six items. The first two subscales are related to public stigma, the next two to personal stigma, and the last two analyse components that may influence people's level of stigma. Also, the scale includes a social desirability dimension, which was not used. Response options for each item range from 0 (*strongly disagree*) to 4 (*strongly agree*). This results in a minimum score of 0 points and a maximum of 24 per subscale. There is no cutoff point for the scores obtained, higher scores indicating greater presence of stigma towards MH.

Procedure

Permission was sought from the original authors of the scale, who authorised the adaptation of the test and its use for research purposes. The translation process for the SASS consisted of three phases (Hambleton and Kanjee, 1995; ITC, 2017; Martínez-Zambrano et al., 2016; Muñoz et al., 2013): a) translation from English to Spanish followed by back-translation carried out by experts with a high level of proficiency in both languages. The back-translation was very similar to the original version, with little discrepancies regarding aspects that did not affect the meaning; b) revision and evaluation of the final Spanish version performed by a group of MH experts, who determined whether the items could be readily understood, and c) implementation of the Spanish version. The Ethical Committee of the University of La Rioja approved this research.

The initial contact with university teachers was made via e-mail, to discuss the possibility to allocate time and develop the study during their classes, ensuring high participation. The instrument was administrated during university classes collectively, through

personal electronic devices. It was carried out by interviewers who had previously been trained by the research team. Participants were explicitly informed about the confidentiality of their responses and voluntary nature of the study. No incentive was provided for their participation. The research was presented to the participants as an investigation concerning their attitude towards MH. There was only anecdotal evidence of non-participation.

Data Analysis

There was no missing data, as the completion of all items of the questionnaire on the platform used was compulsory.

First, descriptive statistics, including means and standards deviations, were computed for the SASS questionnaire.

Second, several confirmatory factor analyses (CFAs) were performed to examine the internal structure of the scale. The one-factor model was tested in addition to the six- and five-dimensions model, based on Docksey et al. (2022). Because the items were measured on 5-point Likert scales and showed non-normal response distributions, the CFA was estimated using the Weighted Least Squares Mean and Variance adjusted (WLSMV) estimator. WLSMV is based on polychoric correlations and provides robust standard errors and adjusted fit indices in moderate sample sizes and models with multiple factors (Li, 2016; Rhemtulla et al., 2012). The following goodness-of-fit indices were used: Chi-square (χ^2), Comparative Fit Index (CFI), Tucker-Lewis Index (TLI), Root Mean Square Error of Approximation (RMSEA) and 90% confidence interval, and Standardized Root Mean Square Residual (SRMR). An RMSEA of .06 or lower is considered a good fit and CFI and TLI values of .90 are considered acceptable for the model fit (Hu & Bentler, 1999). Regarding SRMR, values > .10 may indicate poor fit (Kline, 2016). Finally, the correlations between latent factors were analysed.

Third, reliability of the SASS scores were estimated using Cronbach's α and McDonald's ω (Dunn et al., 2014).

Finally, measurement invariance across gender was evaluated using a sequence of multigroup CFA models (Putnick & Bornstein, 2016; Sireci & Benítez, 2023). First, configural invariance was tested to verify whether the same factor structure held across groups. Next, metric invariance was examined by constraining factor loadings to equality, and scalar invariance was evaluated by additionally constraining item thresholds. The comparison between nested models was based on changes in CFI and RMSEA ($\Delta CFI < .010$ and $\Delta RMSEA < .015$), as recommended for ordinal indicators (Cheung & Rensvold, 2002; Rhemtulla et al., 2012). Only when scalar invariance was supported were latent mean comparisons conducted, since this level of invariance ensures that both the loadings and thresholds are equivalent across groups, allowing differences in latent means to be interpreted as substantive differences in the underlying construct.

The analyses were carried out using SPSS 28.0 (IBM Corp., 2021) and JASP 0.19.3.0 (JASP Team, 2025).

Results

Descriptive Statistics for the SASS Items

Descriptive statistics for the SASS items are shown in Table 1 ($n = 378$). The highest mean score was on item 15 ($M = 2.61$; $SD = 1.21$), and the lowest on item 16 ($M = 0.35$; $SD = 0.78$).

There were several items that had skewness and kurtosis values outside the -1 to 1 range (e.g. items 16, 26 and 41).

Table 1
Descriptive Statistics of the Stigma and Self-Stigma Scales Items

	M_{Boys} (SD)	M_{Girls} (SD)	M (SD)	Skewness	Kurtosis
<i>Stigma to others</i>					
Item16	0.70 (0.99)	0.61 (1.00)	0.64 (0.99)	1.61	1.99
Item21	1.61 (1.13)	0.83 (1.01)	1.13 (1.12)	0.65	-0.55
Item25	0.97 (1.10)	0.72 (1.04)	0.81 (1.07)	1.24	0.70
Item26	0.50 (0.91)	0.26 (0.67)	0.35 (0.78)	2.63	7.32
Item31	1.53 (1.21)	1.27 (1.18)	1.37 (1.20)	0.47	-0.72
Item38	0.61 (1.00)	0.68 (1.05)	0.65 (1.03)	1.45	1.07
<i>Social distance</i>					
Item01	1.55 (1.12)	1.48 (0.98)	1.51 (1.03)	0.47	0.03
Item20	2.21 (1.02)	1.93 (1.34)	2.04 (1.10)	0.11	-0.53
Item28	1.30 (1.20)	1.21 (1.19)	1.25 (1.20)	0.69	-0.37
Item33	2.01 (1.14)	1.76 (1.18)	1.86 (1.17)	0.18	-0.75
Item34	1.10 (1.14)	0.95 (1.20)	1.01 (1.18)	1.03	0.18
Item41	0.78 (1.07)	0.58 (1.12)	0.66 (1.10)	1.74	2.21
<i>Anticipated stigma</i>					
Item02	1.93 (1.40)	1.91 (1.34)	1.92 (1.36)	0.05	-1.18
Item11	1.87 (1.41)	1.84 (1.52)	1.85 (1.48)	0.08	-1.39
Item18	2.17 (1.31)	2.47 (1.22)	2.35 (1.26)	-0.47	-0.74
Item29	1.85 (1.41)	1.85 (1.33)	1.85 (1.36)	0.08	-1.15
Item32	1.63 (1.30)	1.49 (1.27)	1.54 (1.28)	0.35	-0.92
Item37	2.19 (1.38)	2.21 (1.33)	2.20 (1.35)	-0.33	-1.05
<i>Self-stigma</i>					
Item09	1.23 (1.25)	1.06 (1.10)	1.12 (1.16)	0.76	-0.37
Item15	2.58 (1.21)	2.63 (1.20)	2.61 (1.21)	-0.56	-0.55
Item17	2.32 (1.19)	2.18 (1.11)	2.23 (1.14)	-0.24	-0.61
Item19	1.70 (1.20)	1.50 (1.22)	1.57 (1.22)	0.27	-0.79
Item22	1.99 (1.23)	1.70 (1.18)	1.81 (1.20)	-0.01	-0.94
Item40	1.23 (1.22)	0.97 (1.05)	1.07 (1.13)	0.77	-0.24
<i>Avoidant coping</i>					
Item06	1.23 (1.37)	0.93 (1.19)	1.04 (1.27)	0.88	-0.49
Item07	1.19 (1.14)	1.03 (1.17)	1.09 (1.16)	0.76	-0.41
Item10	1.17 (1.48)	0.76 (1.34)	0.91 (1.41)	1.27	0.08
Item14	1.70 (1.20)	2.13 (1.24)	1.97 (1.24)	-0.06	-0.96
Item27	0.74 (0.98)	0.69 (1.06)	0.71 (1.03)	1.42	1.33
Item39	1.32 (1.19)	1.23 (1.17)	1.26 (1.18)	0.55	-0.58
<i>Help-seeking behaviours</i>					
Item03	0.95 (1.16)	0.80 (1.08)	0.86 (1.11)	1.20	0.60
Item05	2.34 (1.35)	2.40 (1.20)	2.38 (1.25)	-0.38	-0.82
Item08	1.19 (1.16)	1.14 (1.15)	1.16 (1.15)	0.69	-0.47
Item12	1.77 (1.30)	1.74 (1.29)	1.75 (1.29)	0.18	-1.01
Item24	1.50 (1.20)	1.13 (1.15)	1.28 (1.18)	0.77	-0.21
Item42	0.68 (1.05)	0.70 (1.05)	0.69 (1.05)	1.39	1.05

Note. M = Mean; SD = Standard deviation. For items translation, refer to the supplementary material through this link: https://osf.io/db3fl/overview?view_only=2f5b6bb8740d40e58eb069d7d169f8c5. Original version of the items is published in Docksey et al. (2022).

Confirmatory Factor Analysis of SASS

For the confirmatory factor analysis, first, the goodness-of-fit indices for one-factor model were computed, indicating a poor fit (see Table 2). Then, a six-factor model was tested yielding poor goodness-of-fit indices. Most of the items from the AC dimension have lower factor loading regarding the cutoff point, so it was considered a five-factor model without it. This model showed

acceptable goodness-of-fit indices. In this regard, it was decided that the optimum solution would be that of five components. The standardized factor loadings for the total sample and by gender are presented in Table 3.

The confirmatory model is illustrated in Figure 1. The strongest correlations between latent factors were among Anticipated stigma (AS) and Self-stigma (SS) with .86, SS and Help-seeking behaviours (HS) with .73, and Stigma to others (SO) and Social distance (SD) with .72. On the other hand, SO and AS showed low correlations with .10, and SD and AS showed negative low correlation with -.09. All the correlations were significant ($p < .005$).

Figure 1
Confirmatory Factor Analysis Model

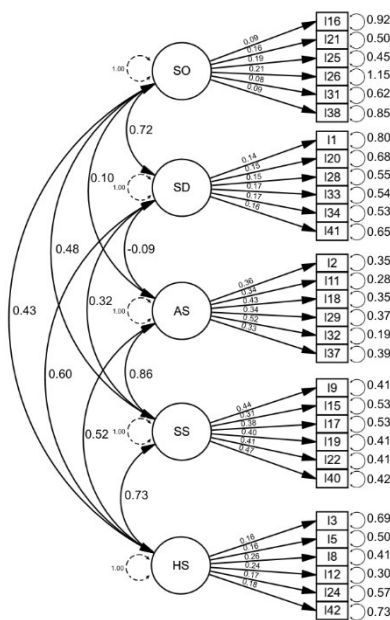

Note. Factor loadings are standardized.

Table 3
Standardized Factor Loadings of the Stigma and Self-Stigma Scales for the Total Sample

Item	One-factor model	Six-factor model	Five-factor model	
	Total	Total	Total	Boys Girls
16	.091	.312	.295	.408 .232
21	.296	.579	.613	.506 .648
25	.341	.705	.699	.745 .657
26	.229	.571	.549	.615 .497
31	.276	.337	.335	.259 .357
38	.137	.337	.318	.574 .213
01	.190	.394	.380	.155 .527
20	.191	.413	.419	.340 .433
28	.168	.463	.467	.299 .538
33	.184	.492	.516	.449 .486
34	.245	.518	.507	.581 .444
41	.206	.461	.458	.355 .464
02	.513	.604	.598	.673 .548
11	.517	.627	.623	.645 .608
18	.508	.660	.663	.734 .634
29	.413	.550	.560	.553 .573
32	.713	.829	.826	.895 .774
37	.405	.537	.542	.582 .519
09	.671	.675	.665	.737 .609
15	.455	.472	.478	.466 .506
17	.535	.557	.564	.600 .537
19	.607	.629	.632	.651 .620
22	.598	.626	.634	.692 .579
40	.681	.690	.680	.700 .654
06	.067	.138		
07	.383	.691		
10	-.032	.048		
14	.298	.375		
27	.326	.579		
39	.071	.144		
03	.325	.414	.395	.494 .299
05	.423	.458	.461	.560 .394
08	.583	.680	.676	.692 .661
12	.589	.681	.712	.748 .701
24	.370	.454	.451	.578 .327
42	.377	.468	.439	.343 .509

Note. All standardized factor loadings estimated were statistically significant ($p < .01$).

Table 2
Goodness-of-fit Indices for the Hypothetical Models Tested and Measurement Invariance of the Stigma and Self-Stigma Scales by Gender

Model	χ^2	df	CFI	TLI	RMSEA (90% CI)	SRMR	$\Delta\chi^2$	Δdf	ΔCFI
One-factor model	2241.635	594	.768	.754	.086 (.082-.090)	.108			
Six-factor model	1269.727	579	.903	.894	.056 (.052-.060)	.080			
Five-factor model	831.202	395	.929	.922	.054 (.049-.059)	.080			
Gender									
Boys (n = 145)	500.091	395	.965	.961	.043 (.030-.054)	.097			
Girls (n = 233)	594.892	395	.938	.931	.047 (.039-.054)	.086			
Configural invariance	1094.982	790	.951	.946	.045 (.039-.052)	.091			
Metric invariance	1176.903	813	.941	.937	.049 (.043-.055)	.093	81.921**	23	.01
Scalar invariance	1251.929	840	.933	.931	.051 (.045-.057)	.093	75.026**	23	< .01

Note. χ^2 = Chi square; df = degrees of freedom; CFI = Comparative Fit Index; TLI = Tucker-Lewis Index; RMSEA = Root Mean Square Error of Approximation; CI = Confidence Interval; SRMR = Standardized Root Mean Square Residual; $\Delta\chi^2$ = change in χ^2 ; ** $p < .001$, indicates significant $\Delta\chi^2$; ΔCFI = Change in Comparative Fit Index. * $\Delta CFI \leq .01$ indicates measurement invariance across gender.

Reliability Estimation of SASS Scores

The SASS subscales showed good reliability. The Cronbach's α were .62 (SD), .64 (SO), .71 (HS), .78 (SS), and .80 (AS), and the McDonald's ω were .60 (SO), .61 (SD), .69 (HS), .77 (SS), and .79 (AS). All item discrimination indices surpassed .30.

Measurement Invariance of SASS Scores Across Gender and Latent Means Comparisons

Given that the five-factor model showed a good fit, the invariance measurement was assessed as a function of gender. There was one additional parameter in the case of the metric invariance, a residual covariance between items 16 and 38. The goodness-of-fit indices for boys and girls were adequate (Table 2). The configural, metric, and scalar measurement invariance models showed an adequate fit to the data. Although the $\Delta\chi^2$ between the constrained and unconstrained models was significant, the Δ CFI was equal or below .01. It was concluded that measurement invariance across gender and the five-factor model was defended, grounded on the Δ CFI.

Latent mean differences across gender groups were estimated from the scalar invariance model. Boys scored higher in almost all dimensions, the exception being AS. These differences were statistically significant only for SO ($d = .553, p < .001$), SD ($d = .394, p < .001$), and SS ($d = .226, p < .001$).

Discussion

This study aimed to expand the understanding of the psychometric properties of the Stigma and Self-Stigma scales, using data from a representative sample of students from the University of La Rioja. The findings provided evidence of validity based on the internal structure of the scale, as well as reliability of the test scores and measurement invariance across gender groups. Structurally, the results supported the original five-factor model, consistent with the findings of the original authors (Docksey et al., 2022).

In this way, the present study provides a reliable detection of the stigma regarding MH problems and help-seeking behaviours toward them as one of the main procedure for its prevention and intervention. Thus, considering the prevalence of MH problems (Leow et al., 2024) and stigma towards it in university students' life, a reliable and valid instrument is needed to comprehensively assess this construct, encompassing stigma related to MH problems, people with them, and help-seeking behaviours.

The findings validated the five-factor structure of the scale within the sample with satisfactory goodness-of-fit indices, providing support to the hypothesis that the assessed construct exhibits a multidimensional nature (Docksey et al., 2022). However, some inconsistencies were found. The Avoidant coping dimension had unacceptable level of internal consistency as in the original version (Docksey et al., 2022), factors with lowest loadings being the ones related to drugs and alcohol use, which could be a cultural factor, this is why this dimension was not introduced in the five-factor model analysis. Regarding the item factor loadings, item 16 fell below the threshold of .30. This could be due to the similarity in redaction with item 38, which could lead to problems in the factorial analysis due to its redundancy (Ferrando & Anguiano-Carrasco, 2010), and exhibit correlated residuals (Bandalos, 2021). This is

why those two redundant items were set as free parameters in the invariance measurement (Husain & Aziz, 2022).

Further evidence of the validity of the measure was provided by the correlations obtained between the five latent dimensions scores of the SASS. Almost all dimensions displayed significantly positive correlations between them. Anticipated stigma and Self-stigma showed the strongest correlation, probably due to the convergence of both of them in the development of the personal stigma construct and how self-stigma influences the anticipated stigma (Fox et al., 2018; Gray et al., 2023; Quinn et al., 2015). As expected, there was a high correlation between Stigma to others and Social distance, as both dimensions constitute a part of public stigma (Corrigan et al., 2014; Lauber et al., 2004). (Lack of) Help-seeking behaviours exhibited significant strong correlations with both Social distance and Self-stigma. Similar patterns have been shown in prior studies, reinforcing the current results regarding Self-stigma and (lack of) Help-seeking behaviours (Evans-Lacko et al., 2012; Shah et al., 2020; Topkaya, 2021). However, there is a scarcity of studies regarding the correlation between (lack of) Help-seeking behaviours and Social distance, as is stated by Yap et al. (2011) and Jorm and Oh (2009). Instead, this phenomenon appears to be more closely related to labelling people with MH problems as a consequence of social distancing (Kosyluk et al., 2020). As a result, individuals may avoid seeking professional help or adhering to treatment in order to prevent social rejection (Hughes et al., 2020; Kosyluk et al., 2020; Sirey et al., 2001), as in the case of social distance. Consequently, the literature usually includes studies using instruments that assess social distance toward people with MH problems and their help-seeking attitudes (Schomerus et al., 2009), a concept also referred to as perceived dependency (Angermeyer et al., 2003). In this regard, this study aims to introduce an instrument designed to analyse these correlations directly and comprehensively. Also, there was a moderate correlation between (lack of) Help-seeking behaviours and Anticipated stigma (Roškar et al., 2022), due to the reluctance for help-seeking in order to avoid identification with the group of people with MH problems (Doll et al., 2021; Pattyn et al., 2014), and with Stigma to others (Özdemir et al., 2023), other studies analysing it in regard with social distance (Colman et al., 2020). Concerning Self-stigma, it had moderate correlations with Stigma to others and Social distance, which was stated also by Shi et al. (2024), due to the relevance of public stigma in the formation of self-stigma, as Stigma to others and Social distance are part of the public stigma dimensionality. Finally, low correlations were found between Anticipated stigma and both Stigma to others and Social distance, the last one with a negative low correlation. Even though Anticipated stigma is part of the self-stigma dimensionality, there is a scarcity of studies which exhibit the relation between Anticipated stigma and public stigma dimensionality. Most of these studies focus on these dimensions regarding help-seeking attitudes (Pattyn et al., 2014; Roškar et al., 2022), and the relation of anticipated stigma to avoid public labelling (Corrigan & Rao, 2012) and discrimination (Masuch et al., 2019). These findings support the first hypothesis of this study, reinforcing the importance of public and personal stigma, and help-seeking behaviours as dimensions for analysing MH stigma.

On this matter, the factors showed satisfactory psychometric properties within the sample. There was satisfactory internal consistency for the SASS factors, as in the original English version (Docksey et al., 2022). The factors proposed coincided with those of the authors and showed acceptable to good reliability and adequate

construct validity, as shown by the correlations observed among the five dimensions, which supported the last hypothesis.

To our knowledge, few studies assessed gender differences and none after performing gender invariance, showing the necessity of this study. In this case, the factorial structure remained invariant across gender groups, suggesting that the latent variables were measured equivalently across all groups, supporting the third hypothesis of this study. So far, only a few studies have examined gender measurement invariance regarding MH stigma dimensions and showed these differences as well, most of them evaluating invariance regarding help-seeking attitudes (Cheng et al., 2024; Goodfellow et al., 2022) or a combination of some of the dimensions analysed in this article (Wu et al., 2015). Also, it is important to state the reduced number of studies that have examined measurement invariance regarding gender in this topic, almost none of them considering the same dimensions as in the SASS that could influence MH stigma. In light of the scarcity of research examining this type of invariance in this instrument, the present study underscores the necessity and significance of addressing this literature gap.

Concerning the differences observed among the latent mean analysis carried out, boys had higher and significant mean scores for Stigma to others, Social distance, and Self-stigma. These results are congruent with those obtained in prior research for the public stigma related to Stigma to others and Social distance (Al Omari et al., 2021; Saavedra & Murvartian, 2021; Sandhu et al., 2019), but there were no studies found regarding Self-stigma. Other studies indicated that public stigma leads to the development of self-stigma related to MH (Vogel et al., 2013). Few studies have examined gender differences across each dimension, as the focus has predominantly been on their association with help-seeking behaviours. Therefore, the present study aims to be a pioneering effort in highlighting these gender-based differences across stigma dimensions.

These findings contributed to a deeper understanding of the dimensions of MH stigma. They may have important implications for the conceptualization, assessment, and development of tailored interventions aimed to reduce MH stigma within educational settings. The distinctive characteristics and perspectives of university students regarding MH make them valuable for investigation in this subject (Koutra et al., 2024). Stigma is an important concept to prevent delay in accessing MH care (Nguyen et al., 2023). In this regard, assessing MH stigma can serve as an initial step toward understanding the nature of the dimensions of stigma and evaluating the stigma perception among university students. This, in turn, enables universities to identify key areas in the students' MH for implementing preventive strategies aimed at promoting MH, following thereby its role (Ley Orgánica 2/2023).

This study's main limitation was the use of only one self-reported questionnaire. Also, the sample belonged to a specific Spanish autonomous community, which may difficult the generalization of the results. Also, the magnitude of some correlations suggests that a more parsimonious model (e.g., a model that comprises three factors) could be plausible. Future research should examine this possibility in larger and more diverse samples to determine whether the multidimensional structure observed here remains stable or if a hierarchical structure provides a better representation of the data. Finally, the gender imbalance represented a constraint, due to boys' prevalence to higher levels of stigma (Dagani et al., 2023; Sum et al., 2024).

The SASS seems to be a brief tool with adequate psychometric properties to assess MH stigma above dimensions that imply public, personal, and help-seeking intentions in university students. In this context, following the approach proposed by Docksey et al. (2022), future studies could analyse stigma among larger groups of university students, doing a comparison among other education levels, and adding qualitative analysis to interpret the bias. The protection and support of young people's MH involves the assessment of MH stigma, to create adaptative programs to promote MH literacy and prevent MH problems.

Author Contributions

Beatrice-Alice Ciulin: Conceptualization, Methodology, Formal analysis, Writing – Original draft. **Alicia Pérez-Albéniz:** Conceptualization, Methodology, Supervision, Writing – Review & editing. **Adriana Díez-Gómez:** Conceptualization, Methodology, Writing – Review & editing. **Beatriz Lucas-Molina:** Formal analysis, Writing – Review & editing. **Rubén Fernández-Alonso:** Formal analysis, Writing – Review & editing.

Funding

This research is part of the I+D+i project PCI2025-163191, funded by MICIU/AEI/10.13039/501100011033/ and co-funded by the European Union. The funding source has not been involved in the design of the study, the collection, analysis or interpretation of data, the writing of the manuscript, or the decision to submit it for publication.

Declaration of Interest

The authors declare that there is no conflict of interest.

Data Availability Statement

Research data associated with the article are not available.

References

- Abdelmonaem, Y. M. M., Osman, M. A., & Karim, N. A. H. A. (2024). Mental health stigma and internship nursing students' attitudes toward seeking professional psychological help: A cross-sectional study. *BMC Nursing*, 23, 275. <https://doi.org/10.1186/s12912-024-01910-3>
- Abdullah, T., & Brown, T. L. (2011). Mental illness stigma and ethnocultural beliefs, values, and norms: An integrative review. *Clinical Psychology Review*, 31(6), 934-948. <https://doi.org/10.1016/j.cpr.2011.05.003>
- Abi Hana, R., Arnous, M., Heim, E., Aeschlimann, A., Koschorke, M., Hamadeh, R. S., Thornicroft, G., Kohrt, B. A., Sijbrandij, M., Cuijpers, P., & El-Chammy, R. (2022). Mental health stigma at primary health care centres in Lebanon: Qualitative study. *International Journal of Mental Health Systems*, 16, 23. <https://doi.org/10.1186/s13033-022-00533-y>
- Al-Halabí, S., & Fonseca-Pedrero, E. (2024). Editorial for special issue on understanding and prevention of suicidal behavior: Humanizing care and integrating social determinants. *Psicothema*, 36(4), 309-318. <https://doi.org/10.7334/psicothema2024.341>
- Al Omari, O., Khalaf, A., Al Sabei, S., Wynaden, D., Ballad, C. A., Al Dameery, K., & Al Qadire, M. (2021). Associated factors of stigma

- toward people with mental illness among university and school students. *Perspectives in Psychiatric Care*, 58(4), 1736-1743. <https://doi.org/10.1111/ppc.12982>
- Al Omari, O., Valsaraj, B. P., Khatatbeh, M., Al-Jubouri, M. B., Emam, M., Al Hashmi, I., Al Qadire, M., Aljezawi, M., ALBashtawy, M., Alkhawaldeh, A., Hasona, A. A., Tarhini, Z., Damra, J., Al Sabei, S., & Mohamed, N. (2023). Self and public stigma towards mental illnesses and its predictors among university students in 11 Arabic-speaking countries: A multi-site study. *International Journal of Mental Health Nursing*, 32(6), 1745-1755. <https://doi.org/10.1111/inm.13206>
- Anderson, A., Giddens, E., Tiego, J., Lubman, D., & Verdejo-Garcia, A. (2024). Leveraging online treatment to re-examine the association between alcohol use and disinhibition. *Psicothema*, 36(1), 15-25. <https://doi.org/10.7334/psicothema2022.516>
- Angermeyer, M. C., Beck, M., & Matschinger, H. (2003). Determinants of the public's preference for social distance from people with schizophrenia. *The Canadian Journal of Psychiatry*, 48(10), 663-668. <https://doi.org/10.1177/070674370304801004>
- Ausín, B., González-Sanguino, C., Castellanos, M. Á., Sáiz, J., Zamorano, S., Vaquero, C., & Muñoz, M. (2022). The psychological impact of the COVID-19 pandemic in Spain: A longitudinal study. *Psicothema*, 34(1), 66-73. <https://doi.org/10.7334/psicothema2021.290>
- Bandalos, D. L. (2021). Item meaning and order as causes of correlated residuals in confirmatory factor analysis. *Structural Equation Modeling: A Multidisciplinary Journal*, 28(6), 903-913. <https://doi.org/10.1080/10705511.2021.1916395>
- Chen, S. X., Mak, W. W. S., & Lam, B. C. P. (2020). Is it cultural context or cultural value? Unpacking cultural influences on stigma toward mental illness and barrier to help-seeking. *Social Psychological and Personality Science*, 11(7), 1022-1031. <https://doi.org/10.1177/1948550619897482>
- Cheng, K., Yang, W., Zhang, Y. H., & She, Z. (2024). Assessing perceptions of stigmatization by others for seeking help in China: Psychometric characteristics and measurement invariance across gender and therapy experience. *Frontiers in Psychology*, 15, 1391239. <https://doi.org/10.3389/fpsyg.2024.1391239>
- Cheung, G. W., & Rensvold, R. B. (2002). Evaluating goodness-of-fit indexes for testing measurement invariance. *Structural Equation Modeling: A Multidisciplinary Journal*, 9(2), 233-255. https://doi.org/10.1207/S15328007SEM0902_5
- Chukwuma, O. V., Ezeani, E. I., Fatoye, E. O., Benjamin, J., Okobi, O. E., Nwume, C. G., & Egberuare, E. N. (2024). A systematic review of the effect of stigmatization on psychiatric illness outcomes. *Cureus*, 16(6), e62642. <https://doi.org/10.7759/cureus.62642>
- Clement, S., Brohan, E., Jeffery, D., Henderson, C., Hatch, S. L., & Thornicroft, G. (2012). Development and psychometric properties the Barriers to Access to Care Evaluation scale (BACE) related to people with mental ill health. *BMC Psychiatry*, 12, 36. <https://doi.org/10.1186/1471-244X-12-36>
- Colman, L., Delaruelle, K., Luypaert, C., Verniest, R., & Bracke, P. (2020). Burdens in mental health recovery: Causal beliefs and their relation to stigma and help seeking recommendations. *International Journal of Social Psychiatry*, 67(8), 992-1004. <https://doi.org/10.1177/0020764020973249>
- Corrigan, P. W., & Rao, D. (2012). On the self-stigma of mental illness: Stages, disclosure, and strategies for change. *The Canadian Journal of Psychiatry*, 57(8), 464-469. <https://doi.org/10.1177/070674371205700804>
- Corrigan, P. W., Druss, B. G., & Perlick, D. A. (2014). The impact of mental illness stigma on seeking and participating in mental health care. *Psychological Science in the Public Interest*, 15(2), 37-70. <https://doi.org/10.1177/1529100614531398>
- Corrigan, P. W., Watson, A. C., & Barr, L. (2006). The self-stigma of mental illness: Implications for self-esteem and self-efficacy. *Journal of Social and Clinical Psychology*, 25(8), 875-884. <https://doi.org/10.1521/jscp.2006.25.8.875>
- Dagani, J., Buizza, C., Ferrari, C., & Ghilardi, A. (2023). The role of psychological distress, stigma and coping strategies on help-seeking intentions in a sample of Italian college students. *BMC Psychology*, 11, 177. <https://doi.org/10.1186/s40359-023-01171-w>
- Dobener, L. M., Fahrer, J., Purtscheller, D., Bauer, A., Paul, J. L., & Christiansen, H. (2022). How do children of parents with mental illness experience stigma? A systematic mixed studies review. *Frontiers in Psychiatry*, 13, 813519. <https://doi.org/10.3389/fpsyg.2022.813519>
- Dobrasky, K. M. (2020). Reassessing mental illness stigma in mental health care: Competing stigmas and risk containment. *Social Science & Medicine*, 249, 112861. <https://doi.org/10.1016/j.socscimed.2020.112861>
- Docksey, A. E., Gray, N. S., Davies, H. B., Simkiss, N., & Snowden, R. J. (2022). The Stigma and Self-Stigma Scales for attitudes to mental health problems: Psychometric properties and its relationship to mental health problems and absenteeism. *Health Psychology Research*, 10(2), 1. <https://doi.org/10.52965/001c.35630>
- Doll, C. M., Michel, C., Rosen, M., Osman, N., Schimmelmann, B. G., & Schultze-Lutter, F. (2021). Predictors of help-seeking behaviour in people with mental health problems: A 3-year prospective community study. *BMC Psychiatry*, 21, 432. <https://doi.org/10.1186/s12888-021-03435-4>
- Drent, H. M., van den Hoofdakker, B., Buitelaar, J. K., Hoekstra, P. J., & Dietrich, A. (2022). Factors related to perceived stigma in parents of children and adolescents in outpatient mental healthcare. *International Journal of Environmental Research and Public Health*, 19(19), 12767. <https://doi.org/10.3390/ijerph191912767>
- Dubreucq, J., Plasse, J., & Franck, N. (2021). Self-stigma in serious mental illness: A systematic review of frequency, correlates, and consequences. *Schizophrenia Bulletin*, 47(5), 1261-1287. <https://doi.org/10.1093/schbul/sbaa181>
- Dunn, T. J., Baguley, T., & Brunnsden, V. (2014). From alpha to omega: A practical solution to the pervasive problem of internal consistency estimation. *British Journal of Psychology*, 105(3), 399-412. <https://doi.org/10.1111/bjop.12046>
- Estupiñá, F. J., Santalla, Á., Prieto-Vila, M., Sanz, A., & Larroy, C. (2024). Mental health in doctoral students: Individual, academic, and organizational predictors. *Psicothema*, 36(2), 123-132. <https://doi.org/10.7334/psicothema2023.156>
- Evans-Lacko, S., Brohan, E., Mojtabai, R., & Thornicroft, G. (2012). Association between public views of mental illness and selfstigma among individuals with mental illness in 14 European countries. *Psychological Medicine*, 42(8), 1741-1752. <https://doi.org/10.1017/s0033291711002558>
- Fernández-Calderón, F., Bravo, A. J., Díaz-Batanero, C., Palamar, J. J., & Carmona-Márquez, J. (2022). Alcohol protective behavioral strategies in young Spanish adults in the community: A prospective study of perceived efficacy and social norms. *Psicothema*, 34(2), 266-274. <https://doi.org/10.7334/psicothema2021.413>
- Ferrando, P. J., & Anguiano-Carrasco, C. (2010). El análisis factorial como técnica de investigación en psicología [Factor analysis as a research technique in psychology]. *Papeles del Psicólogo*, 31(1), 18-33. <https://www.redalyc.org/articulo.oa?id=77812441003>
- Ferreira-Rodrigues, V., Nouvilas-Pallejà, E., Martínez-Huertas, J. A., & Silván-Ferrero, P. (2025). Perceived stigma and psychological well-being in Spanish female survivors of IPVVAW: The role of resilience and attitude toward seeking psychological help. *Current Psychology*, 44,

- 14472-14485. <https://doi.org/10.1007/s12144-025-08143-w>
- Fluharty, M., Bu, F., Steptoe, A., & Fancourt, D. (2021). Coping strategies and mental health trajectories during the first 21 weeks of COVID-19 lockdown in the United Kingdom. *Social Science & Medicine*, 279, 113958. <https://doi.org/10.1016/j.socscimed.2021.113958>
- Fonseca-Pedrero, E., Paino, M., Lemoz-Giraldez, S., Sierra-Baigrie, S., & Muñiz, J. (2011). Measurement invariance of the Schizotypal Personality Questionnaire-Brief across gender and age. *Psychiatry Research*, 190(2-3), 309-315. <https://doi.org/10.1016/j.psychres.2011.05.021>
- Fox, A. B., Smith, B. N., & Vogt, D. (2018). How and when does mental illness stigma impact treatment seeking? Longitudinal examination of relationships between anticipated and internalized stigma, symptom severity, and mental health service use. *Psychiatry Research*, 268, 15-20. <https://doi.org/10.1016/j.psychres.2018.06.036>
- Gabbidon, J., Clement, S., van Nieuwenhuizen, A., Kassam, A., Brohan, E., Norman, I., & Thornicroft, G. (2013). Mental Illness: Clinicians' Attitudes (MICA) Scale – Psychometric properties of a version for healthcare students and professionals. *Psychiatry Research*, 206(1), 81-87. <https://doi.org/10.1016/j.psychres.2012.09.028>
- Gaebel, W., Zäske, H., Cleveland, H. R., Zielasek, J., Stuart, H., Arboleda-Florez, J., Akiyama, T., Gureje, O., Jorge, M. R., Kastrup, M., Suzuki, Y., Tasman, A., & Sartorius, N. (2011). Measuring the stigma of psychiatry and psychiatrists: Development of a questionnaire. *European Archives of Psychiatry and Clinical Neuroscience*, 261(Suppl 2), S119-S123. <https://doi.org/10.1007/s00406-011-0252-0>
- Gilbert, P., Bhundia, R., Mitra, R., McEwan, K., Irons, C., & Sanghera, J. (2007). Cultural differences in shame-focused attitudes towards mental health problems in Asian and non-Asian student women. *Mental Health, Religion & Culture*, 10(2), 127-141. <https://doi.org/10.1080/13694670500415124>
- Goodfellow, C., Macintyre, A., Knifton, L., & Sosu, E. (2022). Associations between dimensions of mental health literacy and adolescent help-seeking intentions. *Child and Adolescent Mental Health*, 28(3), 385-392. <https://doi.org/10.1111/camh.12608>
- Grandón, P., Masedo, A., Saldívia, S., Romero-López-Alberca, C., Bustos, C., Vielma, A., Siprian Castro-Alzate, E., Hervías-Ortega, F., & Moreno-Küstner, B. (2022). Stigma toward people with severe mental disorder in university students before and after their practicum program in mental health. *Professional Psychology: Research and Practice*, 53(1), 14-22. <https://doi.org/10.1037/pro0000415>
- Gray, N. S., Davies, H., Brad, R., & Snowden, R. J. (2023). Reducing sickness absence and stigma due to mental health difficulties: A randomised control treatment trial (RCT) of a low intensity psychological intervention and stigma reduction programme for common mental disorder (Prevail). *BMC Public Health*, 23, 1324. <https://doi.org/10.1186/s12889-023-16200-x>
- Gumus, C. S., & Avci, D. (2024). Relationship between academic teaching staff mental health literacy levels and beliefs toward mental illness. *Archives of Psychiatric Nursing*, 51, 82-88. <https://doi.org/10.1016/j.apnu.2024.05.010>
- Hambleton, R. K., & Kanjee, A. (1995). Increasing the validity of cross-cultural assessments: Use of improved methods for test adaptations. *European Journal of Psychological Assessment*, 11(3), 147-157. <https://psycnet.apa.org/doi/10.1027/1015-5759.11.3.147>
- Hu, L., & Bentler, P. M. (1999). Cutoff criteria for fit indexes in covariance structure analysis: Conventional criteria versus new alternatives. *Structural Equation Modeling: A Multidisciplinary Journal*, 6(1), 1-55. <https://doi.org/10.1080/10705519909540118>
- Hughes, C., Fujita, K., & Krendl, A. C. (2020). Psychological distance reduces the effect of internalized stigma on mental health treatment decisions. *Journal of Applied Social Psychology*, 50(8), 489-498. <https://doi.org/10.1111/jasp.12676>
- Husain, H., & Aziz, H. (2022). Exploratory factor analysis (EFA) and confirmatory factor analysis (CFA) to measure the validity and reliability constructs of historical thinking skills, TPACK and application of historical thinking skills. *International Journal of Education, Psychology and Counseling*, 7(46), 608-623. <https://gaexcellence.com/ijepc/article/view/3481>
- IBM Corp. (2021). *IBM SPSS Statistics* (Versión. 28). [Computer software]. IBM. <https://www.ibm.com/spss>
- International Test Commission (2017). *The ITC Guidelines for Translating and Adapting Tests* (2nd edition). [www.InTestCom.org]
- JASP Team. (2025). *JASP* (Version 0.19.3.0) [Computer software]. JASP. <https://jasp-stats.org/>
- Jorm, A. F., & Oh, E. (2009). Desire for social distance from people with mental disorders. *Australian & New Zealand Journal of Psychiatry*, 43(3), 183-200. <https://doi.org/10.1080/00048670802653349>
- Kim, P. Y., & Yon, K. J. (2019). Stigma, loss of face, and help-seeking attitudes among South Korean college students. *The Counseling Psychologist*, 47(3), 331-357. <https://doi.org/10.1177/0011000019872790>
- Kline, R. B. (2016). *Principles and practice of structural equation modelling* (4th ed.). The Guilford Press.
- Kosyluk, K. A., Conner, K. O., Al-Khouja, M., Bink, A., Buchholz, B., Ellefson, S., Fokuo, K., Goldberg, D., Kraus, D., Leon, A., Powell, K., Schmidt, A., Michaels, P., & Corrigan, P. W. (2020). Factors predicting help seeking for mental illness among college students. *Journal of Mental Health*, 30(3), 300-307. <https://doi.org/10.1080/09638237.2020.1739245>
- Koutra, K., Pantelaiou, V., & Mavroeides, G. (2024). Breaking barriers: Unraveling the connection between mental health literacy, attitudes towards mental illness, and self-stigma of psychological help-seeking in university students. *Psychology International*, 6(2), 590-602. <https://doi.org/10.3390/psycholint6020035>
- Kuhlman, S. T. W., McDermott, R. C., Kridel, M. M., & Kantra, L. M. (2018). College students' peer-helping behaviors and stigma of seeking help: Testing a moderated mediation model. *Journal of American College Health*, 67(8), 753-761. <https://doi.org/10.1080/07448481.2018.1506791>
- Lauber, C., Nordt, C., Falcato, L., & Rössler, W. (2004). Factors influencing social distance toward people with mental illness. *Community Mental Health Journal*, 40(3), 265-274. <https://doi.org/10.1023/B:COMH.0000026999.87728.2d>
- Leow, T., Li, W. W., Miller, D. J., & McDermott, B. (2024). Prevalence of university non-continuation and mental health conditions, and effect of mental health conditions on non-continuation: A systematic review and meta-analysis. *Journal of Mental Health*, 34(2), 222-237. <https://doi.org/10.1080/09638237.2024.2332812>
- Ley Orgánica 2/2023, de 22 de marzo, del Sistema Universitario. *Boletín Oficial del Estado*, núm. 70, de 23 de marzo de 2023, 43267-43339. <https://www.boe.es/eli/es/lo/2023/03/22/2>
- Li, C. H. (2016). The performance of ML, DWLS, and ULS estimation with robust corrections in structural equation models with ordinal variables.

- Psychological Methods*, 21(3), 369-387. <https://doi.org/10.1037/met0000093>
- Link, B. G. (1987). Understanding labeling effects in the area of mental disorders: An assessment of the effects of expectations of rejection. *American Sociological Review*, 52(1), 96-112. <https://www.jstor.org/stable/2095395>
- Link, B. G., & Phelan, J. C. (2001). Conceptualizing stigma. *Annual Review of Sociology*, 27, 363-385. <https://doi.org/10.1146/annurev.soc.27.1.363>
- Madi, H., Abu-Dahab, S., Hamaideh, S. H., & Jarrar, M. (2025). Deliberate self-harm, coping styles, social support among university students in Jordan. *International Journal of Mental Health and Addiction*, 23, 2425-2445. <https://doi.org/10.1007/s11469-023-01237-1>
- Maeshima, L. S., & Parent, M. C. (2022). Mental health stigma and professional help-seeking behaviors among Asian American and Asian international students. *Journal of American College Health*, 70(6), 1761-1767. <https://doi.org/10.1080/07448481.2020.1819820>
- Mak, W. W. S., Poon, C. Y. M., Pun, L. Y. K., & Cheung, S. F. (2007). Meta-analysis of stigma and mental health. *Social Science & Medicine*, 65(2), 245-261. <https://doi.org/10.1016/j.socscimed.2007.03.015>
- Mannarini, S., & Rossi, A. (2019). Assessing mental illness stigma: A complex issue. *Frontiers in Psychology*, 9, 2722. <https://doi.org/10.3389/fpsyg.2018.02722>
- Marek, R. J., Ivezaj, V., Parikh, M. S., Jayade, M., Davila-Shiau, E., & Grilo, C. M. (2023). Factor structure and measurement invariance of the English- versus Spanish-language Eating Disorder Examination Questionnaire: Brief Form (S-EDE-Q-BF) in Hispanic/Latino/a/x persons seeking bariatric surgery. *Surgery for Obesity and Related Diseases*, 19(6), 576-584. <https://doi.org/10.1016/j.soard.2022.12.015>
- Martin, J. K., Pescosolido, B. A., & Tuch, S. A. (2000). Of fear and loathing: The role of 'disturbing behavior', labels, and causal attributions in shaping public attitudes toward people with mental illness. *Journal of Health and Social Behavior*, 41(2), 208-223. <https://www.jstor.org/stable/2676306>
- Martínez-Zambrano, F., Pizzimenti, M., Barbeito, S., Vila-Badía, R., Comellas, G., Escandell, M. J., Hernández, M. J., Fernández-de Corres, B., González-Pinto, A., López-Peña, M. P., Martínez, M., Puig, M., Quilis, J., Vega, P., & Ochoa, S. (2016). Spanish version of the Link's Perceived Devaluation and Discrimination scale. *Psicothema*, 28(2), 201-206. <https://doi.org/10.7334/psicothema2015.89>
- Masuch, T. V., Bea, M., Alm, B., Deibler, P., & Sobanski, E. (2019). Internalized stigma, anticipated discrimination and perceived public stigma in adults with ADHD. *ADHD Attention Deficit and Hyperactivity Disorders*, 11, 211-220. <https://doi.org/10.1007/s12402-018-0274-9>
- Muñiz, J., Elosua, P., & Hambleton, R. K. (2013). International test commission guidelines for test translation and adaption: Second edition. *Psicothema*, 25(2), 151-157. <https://doi.org/10.7334/psicothema2013.24>
- Nguyen, N., Kim, B., & Aronowitz, T. (2023). Factors that influence Asian American college students use of mental health services: A systematic mixed studies review. *Journal of Psychiatric and Mental Health Nursing*, 31(2), 181-202. <https://doi.org/10.1111/jpm.12972>
- Nigusie, K., Tesfaye, D., Bete, T., & Asfaw, H. (2023). Perceived stigma, common mental disorders and associated factors among primary caregivers of adult patients with mental illness attending at public hospitals, Harari regional state, Eastern Ethiopia: A multicenter cross-sectional study. *Frontiers in Public Health*, 11, 1024228. <https://doi.org/10.3389/fpubh.2023.1024228>
- Oexle, N., Müller, M., Kawohl, W., Xu, Z., Viering, S., Wyss, C., Vetter, S., & Rüschi, N. (2018). Self-stigma as a barrier to recovery: A longitudinal study. *European Archives of Psychiatry and Clinical Neuroscience*, 268, 209-212. <https://doi.org/10.1007/s00406-017-0773-2>
- Özdemir, Ö., Kaya, Y., & Adagide, S. (2023). Nursing students' attitudes toward seeking psychological help associated to self-stigma and perceived social stigma. *Journal of Caring Sciences*, 12(4), 221-227. <https://doi.org/10.34172/jcs.2023.33094>
- Paíno, M., González-Menéndez, A. M., Vallina-Fernández, Ó., & Rus-Calafell, M. (2022). A new algorithm for detecting clinical high risk of psychosis in adolescents. *Psicothema*, 34(3), 383-391. <https://doi.org/10.7334/psicothema2022.10>
- Pattyn, E., Verhaeghe, M., Sercu, C., & Bracke, P. (2014). Public stigma and self-stigma: Differential association with attitudes toward formal and informal help seeking. *Psychiatric Services*, 65(2), 232-238. <https://doi.org/10.1176/appi.ps.201200561>
- Pompeo-Fargnoli, A. (2020). Mental health stigma among college students: Misperceptions of perceived and personal stigmas. *Journal of American College Health*, 70(4), 1030-1039. <https://doi.org/10.1080/07448481.2020.1784904>
- Prizeman, K., Weinstein, N., & McCabe, C. (2023). Effects of mental health stigma on loneliness, social isolation, and relationships in young people with depression symptoms. *BMC Psychiatry*, 23, 527. <https://doi.org/10.1186/s12888-023-04991-7>
- Puspitasari, I. M., Garnisa, I. T., Sinuraya, R. K., & Witriani, W. (2020). Perceptions, knowledge, and attitude toward mental health disorders and their treatment among students in an Indonesian university. *Psychology Research and Behavior Management*, 13, 845-854. <https://doi.org/10.2147/PRBM.S274337>
- Putnick, D. L., & Bornstein, M. H. (2016). Measurement invariance conventions and reporting: The state of the art and future directions for psychological research. *Developmental Review*, 41, 71-90. <https://doi.org/10.1016/j.dr.2016.06.004>
- Quinn, D. M., Williams, M. K., & Weisz, B. M. (2015). From discrimination to internalized mental illness stigma: The mediating roles of anticipated discrimination and anticipated stigma. *Psychiatric Rehabilitation Journal*, 38(2), 103-108. <https://psycnet.apa.org/doi/10.1037/prj0000136>
- Rhemtulla, M., Brosseau-Liard, P. É., & Savalei, V. (2012). When can categorical variables be treated as continuous? A comparison of robust continuous and categorical SEM estimation methods under suboptimal conditions. *Psychological Methods*, 17(3), 354-373. <https://doi.org/10.1037/a0029315>
- Ritscher, J. B., Otilingam, P. G., & Grajales, M. (2003). Internalized stigma of mental illness: Psychometric properties of a new measure. *Psychiatry Research*, 121(1), 31-49. <https://doi.org/10.1016/j.psychres.2003.08.008>
- Roškar, S., Kralj, D., Andriessen, K., Krynska, K., Vinko, M., & Podlesek, A. (2022). Anticipated self and public stigma in suicide prevention professionals. *Frontiers in Psychiatry*, 13, 931245. <https://doi.org/10.3389/fpsyg.2022.931245>
- Ruiz, J. C., Fuentes-Durá, I., López-Gilberte, M., Dasí, C., Pardo-García, C., Fuentes-Durán, M. C., Pérez-González, F., Salmeron, L., Soldevila-Matías, P., Vila-Francés, J., & Balanza-Martínez, V. (2022). Public stigma profile toward mental disorders across different university degrees in the University of Valencia (Spain). *Frontiers in Psychiatry*, 13, 951894. <https://doi.org/10.3389/fpsyg.2022.951894>

- Saavedra, J., & Murvartian, L. (2021). Estigma público en salud mental en la universidad [Mental health public stigma at the university]. *Universitas Psychologica*, 20, 1-15. <https://doi.org/10.11144/Javeriana.upsy20.epsm>
- Sanabria-Mazo, J. P., Doval, E., Bernadàs, A., Angarita-Osorio, N., Colomer-Carbonell, A., Evans-Lacko, S., Thornicroft, G., Luciano, J. V., & Rubio-Valera, M. (2023). Over 40 years (1981–2023) assessing stigma with the Community Attitudes to Mental Illness (CAMI) scale: A systematic review of its psychometric properties. *Systematic Reviews*, 12, 66. <https://doi.org/10.1186/s13643-023-02230-4>
- Sandhu, H. S., Arora, A., & Brasch, J. (2019). Correlates of explicit and implicit stigmatizing attitudes of Canadian undergraduate university students toward mental illness: A cross-sectional study. *Journal of American College Health*, 69(5), 567-571. <https://doi.org/10.1080/07448481.2019.1682002>
- Sastre-Rus, M., Tomás-Sábado, J., Juliá-Sanchis, R., Roldán-Merino, J. F., Puig-Llobet, M., & Lluch-Canut, M. T. (2020). Development and psychometric testing of a scale for assessing the associative stigma of mental illness in nursing. *Journal of Clinical Nursing*, 29(21-22), 4300-4312. <https://doi.org/10.1111/jocn.15467>
- Scerri, J., Sammut, A., & Agius, J. (2023). A sociocultural perspective of mental health stigma in Malta. *Frontiers in Psychiatry*, 14, 1229920. <https://doi.org/10.3389/fpsy.2023.1229920>
- Schomerus, G., Matschinger, H., & Angermeyer, M. C. (2009). The stigma of psychiatric treatment and help-seeking intentions for depression. *European Archives of Psychiatry and Clinical Neuroscience*, 259, 298-306. <https://doi.org/10.1007/s00406-009-0870-y>
- Shah, B. B., Niewegowski, K., & Corrigan, P. W. (2020). Perceptions of difference and disdain on the self-stigma of mental illness. *Journal of Mental Health*, 31(1), 22-28. <https://doi.org/10.1080/09638237.2020.1803231>
- Shannon, A., Flett, G. L., & Goldberg, J. O. (2020). Feelings of not mattering, perceived stigmatization for seeking help, and help-seeking attitudes among university students. *International Journal of Mental Health and Addiction*, 18, 1294-1303. <https://doi.org/10.1007/s11469-019-00138-6>
- Shannon, J., Seward, D. X., Liu, Y., & Luke, M. (2022). Stigma, help-seeking, and counseling with African American male college students. *Journal of Counseling & Development*, 100(4), 421-432. <https://doi.org/10.1002/jcad.12435>
- Shi, X., Sun, X., Zhang, C., & Li, Z. (2024). Individual stigma in people with severe mental illness: Associations with public stigma, psychological capital, cognitive appraisal and coping orientations. *Comprehensive Psychiatry*, 132, 152474. <https://doi.org/10.1016/j.comppsy.2024.152474>
- Sireci, S., & Benítez, I. (2023). Evidence for test validation: A guide for practitioners. *Psicothema*, 35(3), 217-226. <https://doi.org/10.7334/psicothema2022.477>
- Sirey, J. A., Bruce, M. L., Alexopoulos, G. S., Perlick, D. A., Friedman, S. J., & Meyers, B. S. (2001). Stigma as a barrier to recovery: Perceived stigma and patient-rated severity of illness as predictors of antidepressant drug adherence. *Psychiatric Services*, 52(12), 1615-1620. <https://doi.org/10.1176/appi.ps.52.12.1615>
- Sum, M. Y., Chan, S. K. W., Tsui, H. K. H., & Wong, G. H. Y. (2024). Stigma towards mental illness, resilience, and help-seeking behaviours in undergraduate students in Hong Kong. *Early Intervention in Psychiatry*, 18(3), 181-189. <https://doi.org/10.1111/eip.13455>
- Taylor, S. M., & Dear, M. J. (1981). Scaling community attitudes toward the mentally ill. *Schizophrenia Bulletin*, 7(2), 225-240. <https://doi.org/10.1093/schbul/7.2.225>
- Tisocco, F., Nearchou, F., Hennessy, E., & Fernández Liporace, M. (2024). The peer mental health stigmatization scale-revised (PMHSS-R): Psychometric properties and cross-cultural factorial invariance in university students in Ireland and Argentina. *Early Intervention in Psychiatry*, 18(9), 766-770. <https://doi.org/10.1111/eip.13588>
- Topkaya, N. (2021). Predictors of attitudes toward seeking professional psychological help among Turkish college students. *Children and Youth Services Review*, 120, 105782. <https://doi.org/10.1016/j.childyouth.2020.105782>
- Trigueros, R., Navarro Gómez, N., Aguilar-Parra, J. M., Cangas Díaz, A. J., & Ortiz Jiménez, L. (2019). Adaptation and validation of the scale of Self-Stigma in Relatives of People with Mental Illness to the Spanish context. *Anales de psicología*, 35(3), 371-377. <https://doi.org/10.6018/analesps.35.3.343641>
- Vogel, D. L., Bitman, R. L., Hammer, J. H., & Wade, N. G. (2013). Is stigma internalized? The longitudinal impact of public stigma on self-stigma. *Journal of Counseling Psychology*, 60(2), 311-316. <https://doi.org/10.1037/a0031889>
- Vogel, D. L., Wade, N. G., & Ascherman, P. L. (2009). Measuring perceptions of stigmatization by others for seeking psychological help: Reliability and validity of a new stigma scale with college students. *Journal of Counseling Psychology*, 56(2), 301-308. <https://doi.org/10.1037/a0014903>
- Vogel, D. L., Wade, N. G., & Haake, S. (2006). Measuring the self-stigma associated with seeking psychological help. *Journal of Counseling Psychology*, 53(3), 325-337. <https://doi.org/10.1037/0022-0167.53.3.325>
- Wang, K. (2022). The yin-yang definition model of mental health: The mental health definition in Chinese culture. *Frontiers in Psychology*, 13, 832076. <https://doi.org/10.3389/fpsyg.2022.832076>
- Ward-Ciesielski, E. F., Limowski, A. R., Kreper, S. M., & McDermott, M. J. (2019). Relationships between treatment attitudes, psychological symptoms, emotional competence, and help-seeking intentions. *Journal of Counseling & Development*, 97(3), 250-259. <https://doi.org/10.1002/jcad.12265>
- Wu, T. H., Chang, C. C., Chen, C. Y., Wang, J. D., & Lin, C. Y. (2015). Further psychometric evaluation of the Self-Stigma Scale-Short: Measurement invariance across mental illness and gender. *PLoS ONE*, 10(2), e0117592. <https://doi.org/10.1371/journal.pone.0117592>
- Yap, M. B. H., Wright, A., & Jorm, A. F. (2011). The influence of stigma on young people's help-seeking intentions and beliefs about the helpfulness of various sources of help. *Social Psychiatry and Psychiatric Epidemiology*, 46, 1257-1265. <https://doi.org/10.1007/s00127-010-0300-5>
- Zayts-Spence, O., Edmonds, D., & Fortune, Z. (2023). Mental health, discourse and stigma. *BMC Psychology*, 11, 180. <https://doi.org/10.1186/s40359-023-01210-6>
- Zhang, Z., Sun, K., Jatchavala, C., Koh, J., Chia, Y., Bose, J., Li, Z., Tan, W., Wang, S., Chu, W., Wang, J., Tran, B., & Ho, R. (2020). Overview of stigma against psychiatric illnesses and advancements of anti-stigma activities in six Asian societies. *International Journal of Environmental Research and Public Health*, 17(1), 280. <https://doi.org/10.3390/ijerph17010280>